

# Axiotech vario

## Freedom to move



**The microscope for large, heavy samples  
in quality control, materials analysis, and  
materials development**



## Ready for big demands

Materials research, development, and analysis, together with quality control and assurance, are continually placing new demands on materials microscopy. Conventional microscopes reach their limits when it comes to the examination of large, heavy, or bulky samples. This is where Carl Zeiss steps in – with a microscope that combines precision, stability, and flexibility. Its name: Axiotech vario, the specialist for non-standard size samples. It features a large continuously adjustable specimen area and baseplate with a grid pattern of holes – guaranteeing you maximum flexibility for your needs and your experimental set-ups. Axiotech vario offers even more: the option of precisely determining sizes laterally and vertically with the 3-axis measuring system from Carl Zeiss. In addition, you can integrate Axiotech vario as a high-performance core in a digital imaging platform. Axiotech vario – for fast and direct results.



vario



## A flexible design

**Stability and variability:** Axiotech vario easily fulfills the demands placed on the microscopic analysis of bulky samples. Whatever stand you decide for, you can be assured of robust, vibration-free construction and a design that guarantees you freedom of manipulation in three important respects. First, through continuous vertical adjustment of the microscope body. Second, through an impressive diversity of adaptation options. Third, through the sophisticated modular design, which enables you to tailor Axiotech vario to the specific demands of your applications.

### **The stands: Size is decisive**

Flexibility times two: With Axiotech vario, you can decide on the stand that best meets your requirements – the standard model with a height up to 380 mm and the special applications model with a height up to 640 mm. They both offer you an important advantage: a crank on the top of the stand column which permits easy and safe adjustment of the microscope body on the stand – continuously and without any tools.

### **Stability and flexibility: Opposites attract**

Consistently vibration-free – with its heavy metal baseplate, the unique construction of the stand column meets all your demands for stability, no matter how high the sample is. Simultaneously the grid pattern of holes in the baseplate and the sophisticated modular construction make it easy for you to retrofit Axiotech vario to meet your needs – for various specimens and techniques and for almost all areas of application.



# Axiotech vario

## Reflected or transmitted light?

### Both available

Standard reflected light illumination is 100 watts. The transmitted light equipment is even more powerful. Axiotech vario provides a 6 V, 30 W halogen lamp, which is mounted on the baseplate and attached to an external power supply unit. Designed for objective magnifications up to 20x, the transmitted light equipment illuminates areas up to a diameter of 19 mm with bright and even light. It is also available with a polarizer, both swivelling and rotatable

## Easy orientation: The full picture

Upright and laterally correct – that's how you see your materials specimens with Axiotech vario. The advantages are obvious. The view of the specimen and the image in the microscope fit together – ideal for fast orientation and accelerated workflow (e.g. in quality control). All of this is in a 23 mm field of view.

## White cast iron

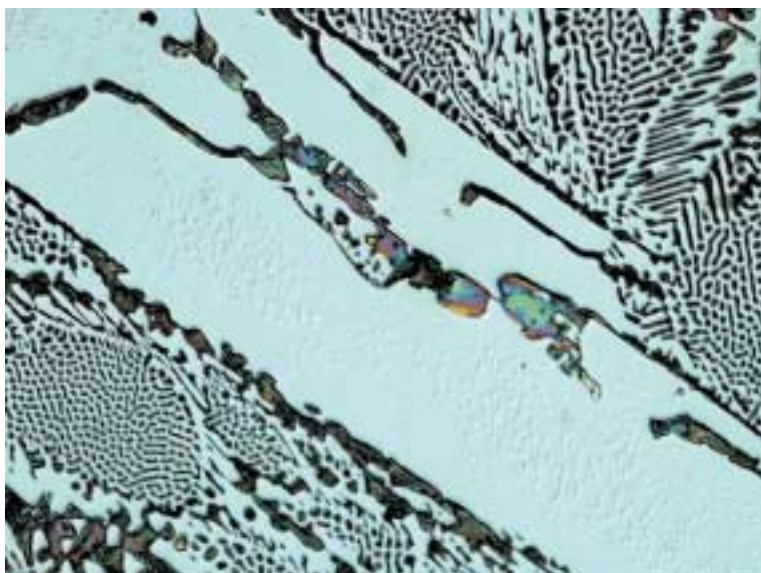

*White cast iron: primary cementite  $Fe_3C$  and ledeburite, hypereutectic pig iron. Etching: Nital (EC Epiplan-Neofluar 20x/0.50 HD DIC). Photo: E. Helmke, Institute for Welding Engineering, Technical University Braunschweig.*

*Composite material, EC Epiplan-Neofluar 20x/0.50 HD DIC, reflected light-DIC*



# The objective leap forward

Resolution, transmission, contrast, working distance – no matter what the decisive factor for your applications is, Carl Zeiss objectives will meet your demands. The impressive array of objectives includes time-tested Epiplans, EC Epiplan-Apochromats and special application objectives in addition to the innovative and unique EC Epiplan-Neofluars. With the development of these objectives, Carl Zeiss has set new standards of performance. The innovative materials objectives provide everything that optics can deliver in contrast and resolution. Axiotech vario is designed in all its details for the specific optical demands of materials applications. A wide range of contrasting and measuring techniques is part of the high-performance Axiotech vario package.

## **Enhanced contrast: The best in color and contrast**

Outstanding contrast and excellent imaging – the Enhanced Contrast Epiplan-Neofluars. Based on ICS optics, these objectives offer the finest quality available in materials microscopy. Their long working distances and high numerical apertures are ideal for all relevant contrasting techniques, such as brightfield, darkfield, DIC and polarization. High contrast makes these objectives perfect for capturing clear, sharp images for post processing and subsequent analysis. All in all, they provide an outstanding basis for the use of high-resolution digital cameras.

## **LD EC Epiplan-Neofluars: Safe distance**

Ample room for illumination and manipulation: the LD EC Epiplan-Neofluar objectives provide you with increased working distances. They offer you yet another benefit: your specimens and objectives are largely protected against damage – even if a job has to be done fast.

*\*LD: Long Distance*



**Brightfield**



# Axiotech vario



Cast material G-X5 CrNiMoNb 18 10, electrolytically etched with lead acetate. Blue: delta ferrite; red: sigma phase; white-yellow: NbC. Reflected light-brightfield, EC Epiplan-Neofluar 20x/0.50 HD DIC. Photo: E. Helmke, Institute for Welding Engineering, Technical University Braunschweig.

## Contrasting techniques:

### Advantages included

Brightfield, darkfield, polarization, DIC (Differential Interference Contrast) – Axiotech vario provides you with all important contrasting techniques in reflected light. In addition, high contrast ensures that materials defects are visible at a glance – in an image quality so brilliant that no detail is hidden.

### DIC: One for all

Especially for DIC: a height-adjustable prism for all Epiplan and EC Epiplan-Neofluar objectives in the ICS category. Your benefits: rich contrast, high resolution, easy operation, and an attractive price.

### Fluorescence: Brilliance is the key

Whether testing wafers for contamination or metal parts for traces of oil and grease: fluorescence is the suitable technique here. And Axiotech vario is the appropriate microscope – with fluorescence equipment in renowned Carl Zeiss quality, a wide range of excitation and emission filters, and special application lamps of varying strengths for ideal lighting conditions.

DIC: a prism for all objectives.



### Stereomicroscopy: For an added dimension

Seeing objects through the eyepiece or on the monitor as they really are – in real time and 3D. This stereoscopic effect is possible with a special illumination slider, together with matching eyepieces. An additional advantage: 12% higher lateral resolution in contrast to conventional images!

Darkfield



DIC



Fluorescence

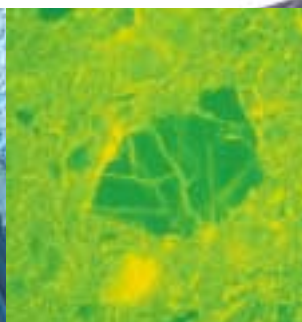

Stereoscopic image

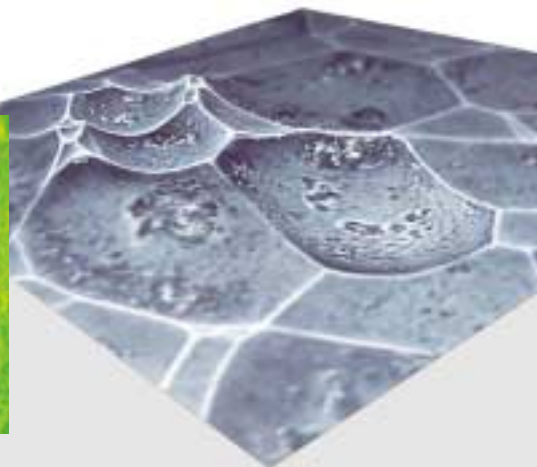

Axiotech vario: flexible for all important contrasting techniques.

# High standards

Measuring, calculating, comparing, and statistical evaluations are all standard tasks in quality control. Carl Zeiss offers a wealth of measuring and evaluation techniques for Axiotech vario, so that you can precisely examine your materials samples. Starting with measuring and grain-sizing disks, a digital micrometer eyepiece, the microhardness tester MHT 4/10, and the new 3-axis measuring system right up to automatic image analytical recording and evaluation with AxioVision. Axiotech vario – the right accessories for every application.



*Vickers hardness indentation in cast material, EC Epiplan-Neofluar 50x/0.80, HD DIC, reflected light DIC.  
Photo: E. Helmke, Institute for Welding Engineering, Technical University Braunschweig.*

## 3-axis measuring system: Data with precision

A routine task in quality control is the fast measurement of size parameters laterally and vertically under the microscope. An elegant and easy solution: the 3-axis measuring system from Carl Zeiss. A mechanical stage with electronic verniers permits  $\mu\text{m}$ -precise measurements. In addition, the exact height of the structure is selected. Measurement data are shown directly on the display or on the monitor. The result: you now have easy access to the exact measurement data of all three spatial axes. With reproducible results and precision down to  $1\ \mu\text{m}$ , depending on the magnification used.

## Microhardness testing: A perfect impression

On the one hand, precise results, on the other hand, many work-saving advantages – microhardness testing with Axiotech vario. There are two versions: MHT 10 for testing from 0.5 to 400 p and MHT 4 from 0.05 to 200 p. Each version has its own exchangeable diamond tip (Vickers or Knoop). Identical interfaces (dimensions, thread) make it easy and convenient to attach the testers instead of an objective.

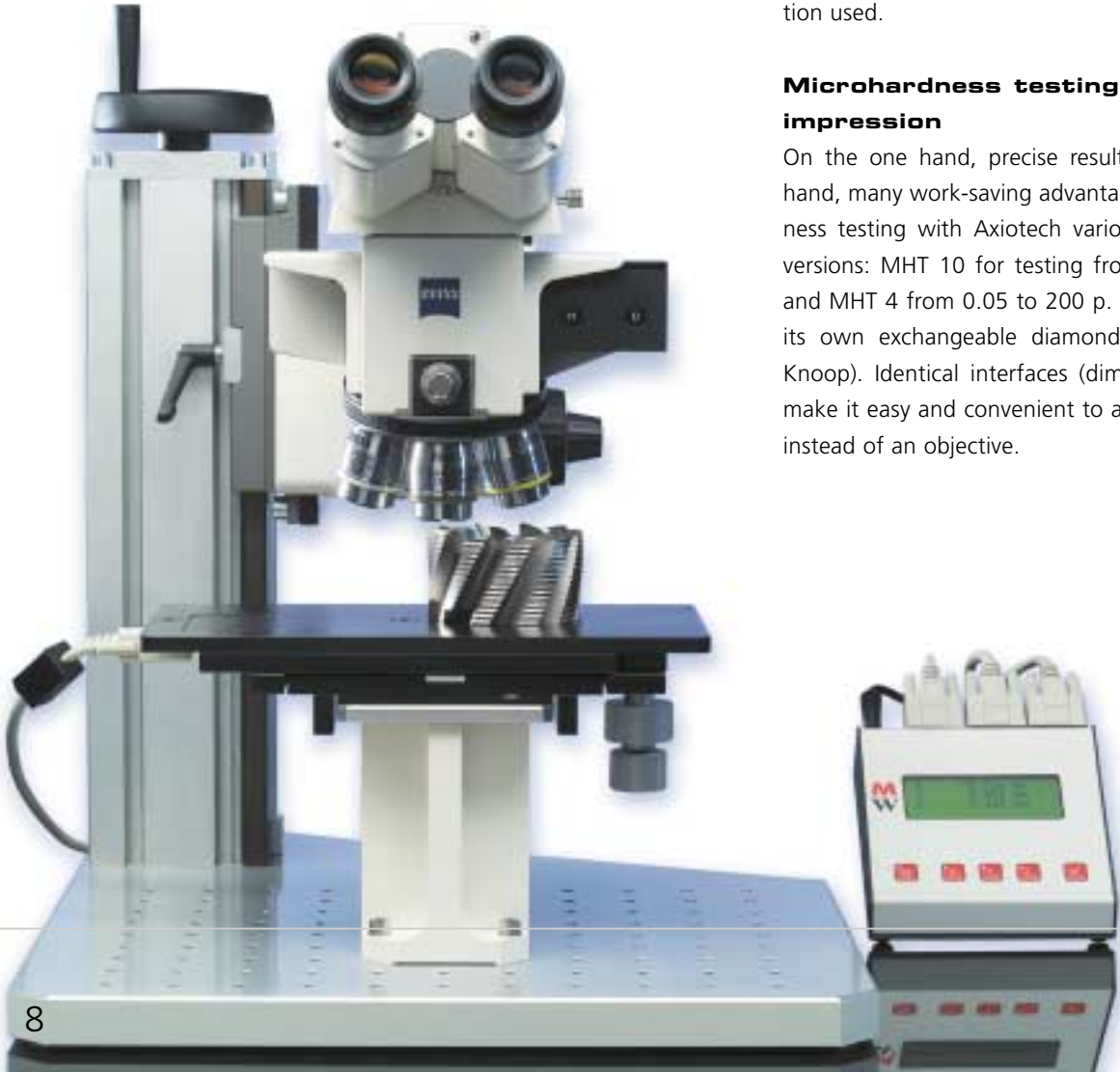

*With  $\mu\text{m}$  precision: the 3-axis measuring system from Axiotech vario offers measuring data on all three dimensions.*



*Etched steel surface, EC Epiplan-Neofluar  
20x/0.50, HD DIC, reflected light DIC.*



**The system: 100% integration**

Integrated solutions in microscopy – that's what Carl Zeiss stands for. Complete digital imaging systems comprising microscopes, accessories, cameras, and software as well as sales and service support. 100% integration, 100% compatible. These are advantages that only Carl Zeiss can offer you, advantages you will benefit from. With only one Carl Zeiss specialist as your contact, you get individualized attention and fast answers to your questions. And you get systems solutions that not only work effectively from the start but are reliable, retrofittable, and a safe investment in your future.

**The cameras: AxioCam**

You can attach a wide variety of cameras to Axiotech vario. Your entry into the world of digital image processing and documentation? Best

accomplished with the AxioCam digital cameras from Carl Zeiss. Perfectly matched to the microscopes and measuring equipment, suitable for every task in materials microscopy, low end as well as high end. With impressive advantages: high resolution, outstanding results, compact size, and easy operation.

**AxioVision software: Modular top performance**

Developed for all documentation requirements in quality assurance and materials science: AxioVision, the software from Carl Zeiss. Even the basic module contains all the important functions you need for digital image processing, analysis and archiving. With the addition of further modules, you can customize a software package to meet all the requirements of your lab – efficiently and economically.



# Axiotech vario - systems overview

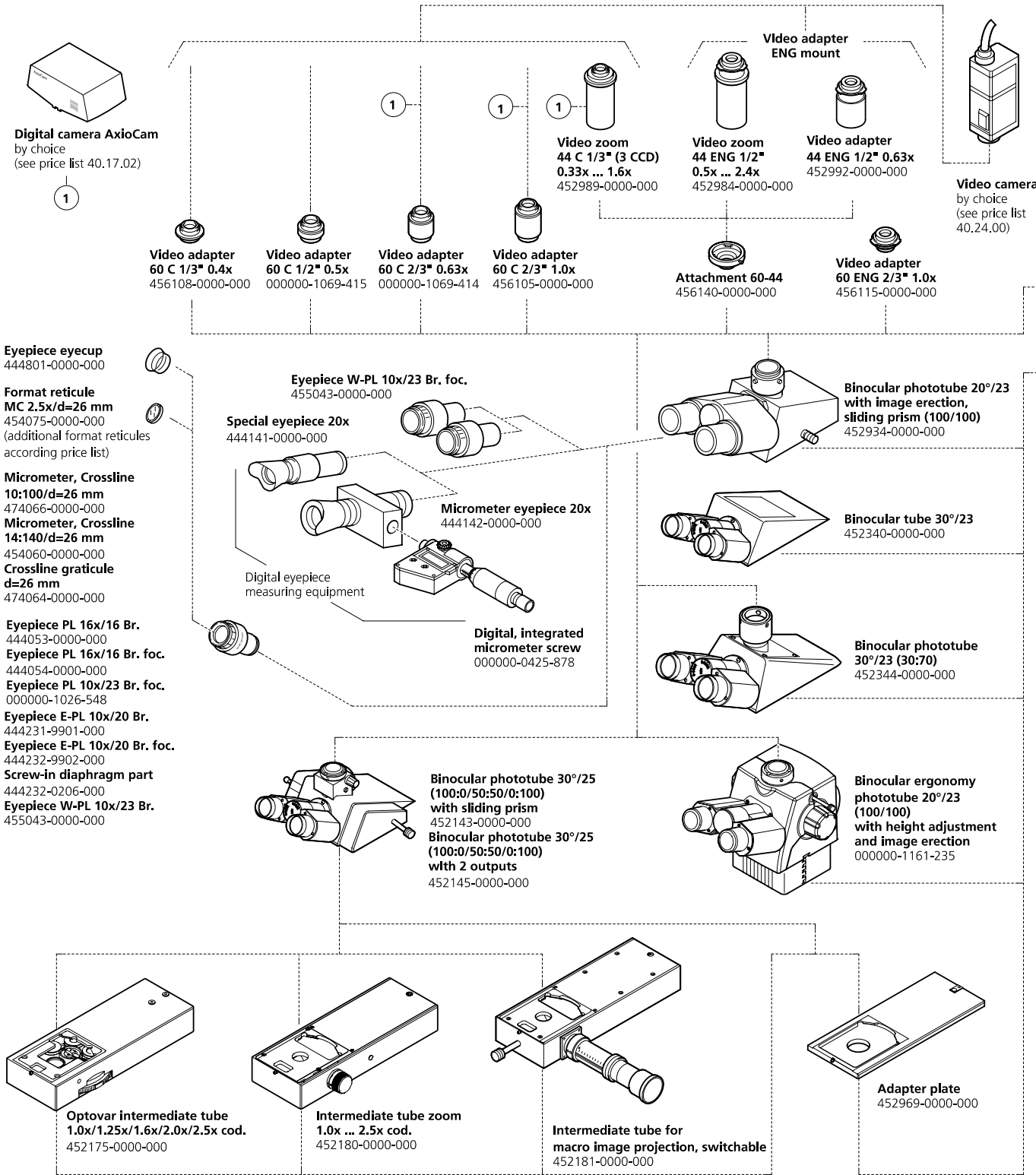



**SLR camera housing**  
by choice  
(see price list 40.24.00)

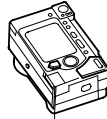

**Compact digital camera**  
by choice  
(see price list 40.24.00)



**T2 adapter**  
by choice  
(see price list 40.24.02)

**Digital camera adapter  
D 40 M37/52x0.75**  
000000-1096-522

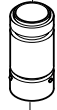

**Digital camera adapter  
44 M52x0.75**  
000000-1108-984



**Adapter for SLR camera  
2.5x for T2**  
456005-0000-000

**Adapter 60 for  
microscope camera,  
d=30 mm**  
456006-0000-000



**Adapter 60-44**  
456140-0000-000

**Microscope camera  
MC 200 CHIP**  
(see price list 40.24.00 for  
equipment and accessories)

**Switching mirror  
for 2 illuminators**  
447230-9901-000

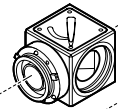

**Power supply  
for HBO 50 ac**  
000000-1113-3



**DIC prism**  
444410-0000-000  
for Epiplan and  
EC-Epiplan-Neofluar objectives  
**DIC prism**  
444411-0000-000  
for Epiplan, Epiplan-Neofluar  
and  
EC-Epiplan-Neofluar objectives

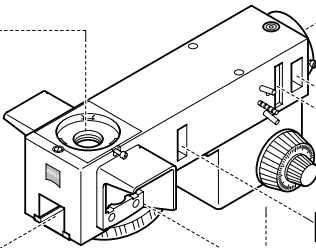

**Microscope body  
Axiotech vario 100**  
451032-9902-000  
with  
5-position nosepiece HD M27,  
incident light equipment 100 HD,  
coaxial drive,  
column clamping X95  
suitable for DIC,  
polarization contrast and 3D-image

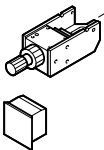

**Filter with 32 mm dia.**  
according to price list



**Filter slider**  
(contained in stand)

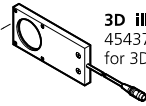

**3D illuminator shutter**  
454370-0000-000  
for 3D image microscopy

**Illuminated field  
diaphragm slider**  
(contained in stand)



**Reflector slider 3 FL**  
446344-0000-000  
**Reflector slider 2 FL/3D**  
000000-1034-926

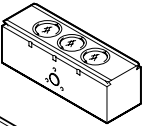

**Slider D Pol**  
000000-1052-384

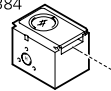

**Reflector slider HD**  
446343-0000-000



**Analyzer slider  
rotatable ±10°**  
453686-0000-000



**Reflector slider  
HD DIC**  
446342-0000-000

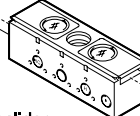

**Compensator  
Lambda**  
453707-0000-000



**Compensator Pol  
Lambda sub. ±10°**  
453706-0000-000

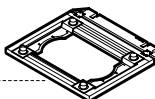

**Universal mounting frame for  
Petri dishes and specimen slide**  
000000-1100-843

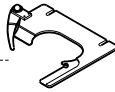

**Specimen holder KT 75x50,  
for one-hand operation**  
000000-1172-575

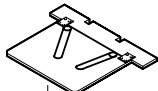

**Specimen holder A  
for reflected light**  
433411-0000-000



**Specimen holder  
with Spring Finger R**  
473448-0000-000

**Specimen holder special**  
453538-0000-000  
**Universal mounting frame for  
Petri dishes and specimen holder**  
453545-0000-000  
(see price list for other specimen holders)

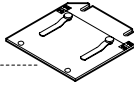

**Specimen holder, reflected light**  
000000-1070-588

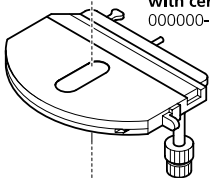

**Mechanical stage 75x50/240° R  
with ceramic coating**  
000000-1142-561

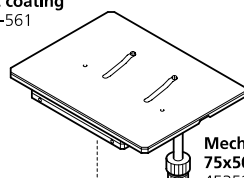

**Mechanical stage  
75x50, right**  
453527-0000-000



**Incident light measuring stage  
105x105 R \***  
000000-1223-326  
(with display unit SCD  
413507-9001-000)

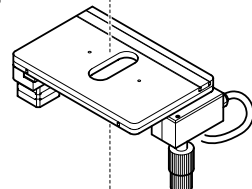
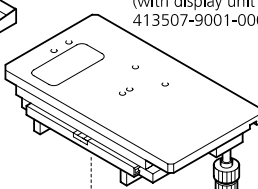

**Mechanical stage  
75x50 mot  
with control unit**  
000000-1025-145

optional:  
**Joystick for 2 axes**  
000000-1033-996  
or  
**Coaxial electronic drive**  
000000-1034-960

**Transmitted-I**  
451051-0000-0

\* or in connection with Z measuring device for Axiotech vario 451022-0000-000 and SCD5 display unit 000000-1223-336

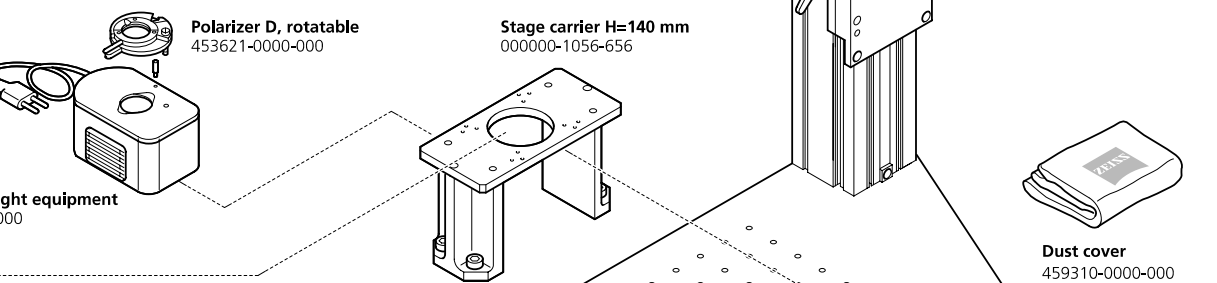
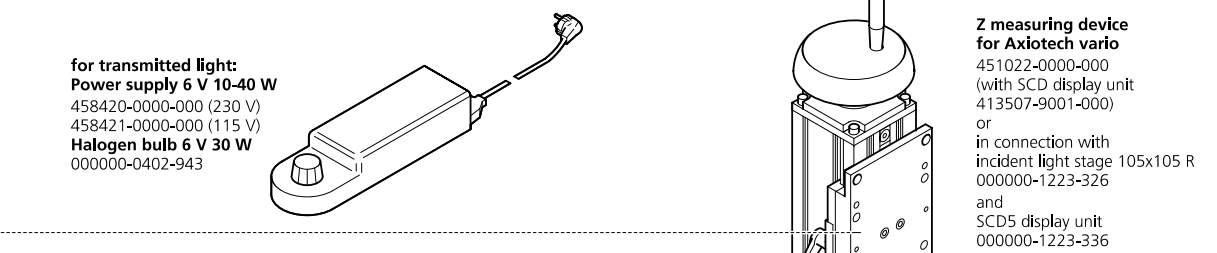
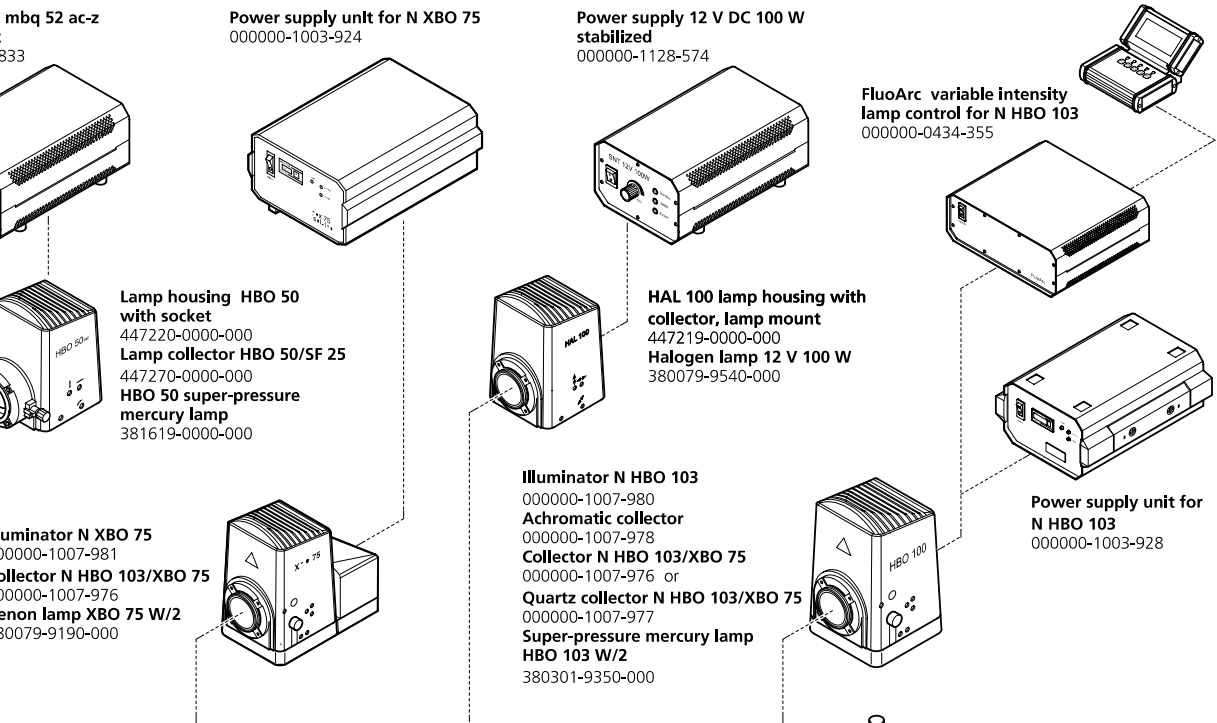

**380 mm stand for Axiotech vario**  
451014-9901-000  
with  
base plate 396 mm x 440 mm  
and crank handle for height adjustment

**640 mm stand for Axiotech vario**  
451013-0000-000  
with  
base plate 396 mm x 440 mm  
and crank handle for height adjustment

# Facts and figures - Axiotech vario in detail

<b>Stands</b>	Column height either 380 mm (standard) or 640 mm (special applications); functional baseplate with grid hole pattern. Floor space: 396x440 mm
<b>Microscope body</b>	5x bright- and darkfield nosepiece (M27), reflected light beam path
<b>Contrasting techniques</b>	Reflected light: brightfield, darkfield, polarization contrast, DIC, fluorescence Transmitted light: brightfield, polarization contrast
<b>Objectives</b>	Reflected light: Epiplan, EC Epiplan-Neofluar Special application: LD objectives (Long Distance), immersion objectives Transmitted light: CP-Achromat, A-Plan, Plan-Neofluar
<b>Eyepieces</b>	W-PL 10x/23 Br Foc
<b>Stages</b>	Mechanical stages 75x50 mm with left and right coaxial drive; mechanical stage 75x50 mm, 240° rotatable, scanning stage; reflected light measuring stage 105x105 mm
<b>Measuring system</b>	3-axis measuring system
<b>Documentation</b>	Tubes: binocular phototube (Siedentopf principle), 20°/23, 100vis/100doc Camera: AxioCam family Adapters: For a wide range of cameras Software: Camera software, AxioVision

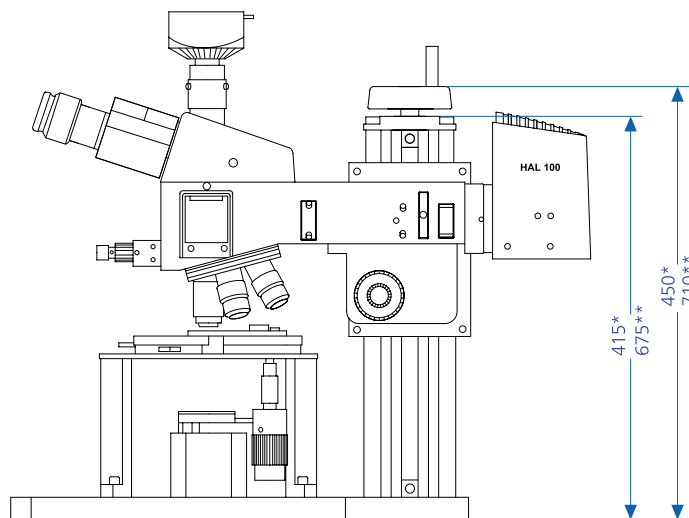

\* Stand 380 mm for Axiotech vario

\*\* Stand 640 mm for Axiotech vario

Floor space: 396x440 mm

Free distance optical axis-column

surface: 160 mm

# **Axiotech vario**

## **- high performance point by point**

- 
- Robust: The materials microscope for large, heavy, and bulky samples
- 
- New heights: Two stand versions with 380 mm and 640 mm column height
- 
- Variable: Accommodates broad diversity of adaptations
- 
- Good investment: Economical modular system
- 
- Renowned: Carl Zeiss ICS optics
- 
- Leading: EC Epiplan-Neofluar materials objectives
- 
- Practice-driven: Upright, laterally correct image, large 23 mm field of view
- 
- High contrast: Wide array of contrasting techniques
- 
- 3-dimensional: Stereomicroscopy for 3D effects
- 
- Analytically precise: All important measuring techniques, innovative 3-axis measuring system
- 
- Flexible: Complete integration into modern digital imaging systems
- 

### **Carl Zeiss Light Microscopy**

P.O.B 4041  
37030 Göttingen  
GERMANY  
Phone: +49 551 5060 660  
Telefax: +49 551 5060 464  
E-Mail: [micro@zeiss.de](mailto:micro@zeiss.de)

**[www.zeiss.de/mat](http://www.zeiss.de/mat)**

Subject to change